

NOTES:

1. MATERIAL:
 - 1.1 HOUSING: THERMOPLASTIC, HIGH TEMP.UL94V-0; COLOR:WHITE.
 - 1.2 ACTUATOR: THERMOPLASTIC, HIGH TEMP.UL94V-0; COLOR:BLACK.
 - 1.3 CONTACT: COPPER ALLOY
 - 1.4 FITTING NAIL: COPPER ALLOY
2. FINISH:
 - 2.1 CONTACT:
 - 1.GOLD FLASH PLATING .
 - 50u" MIN. NICKEL UNDERPLATING OVERALL.
 - M: 50~120u" NICKEL PLATING OVERALL
 - 3u" MIN. GOLD PLATING ON CONTACT
 - 1u" MIN. PLATING GOLD ON SMT
 - 2.2 FITTING NAIL:
 - 100~200u" TIN PLATING ON SOLDER TAILS(LEAD FREE).
 - 50~100u" NICKEL UNDERPLATING OVERALL.
3. SPEC. PLS. REFER TO PS-50696-XXXX-001
4. PACKAGE PLS. REFER TO 51538-XXXX-TRP

5. PART NUMBER

51538-XXX X X-001

NO OF CKT | CONTACT PLATING
 PACKING | 1: G/F (LEAD FREE)
 0:TAPE REEL | M:3u" GOLD ON CONTACT AND SOLDER FOR
 1:TUBE | SELECTIVENESS PLATING

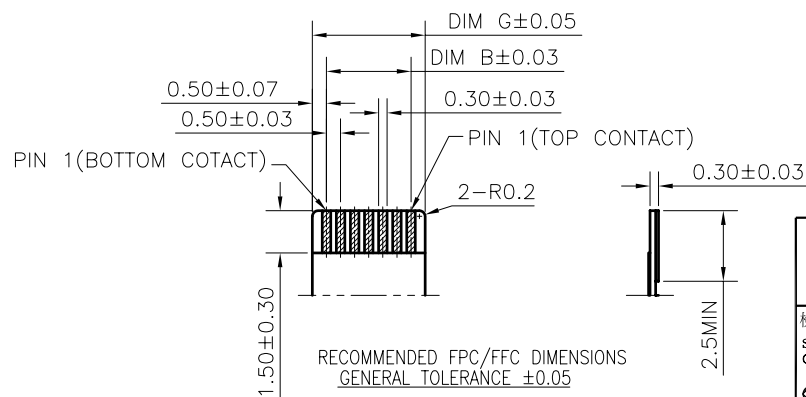
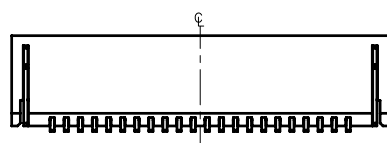
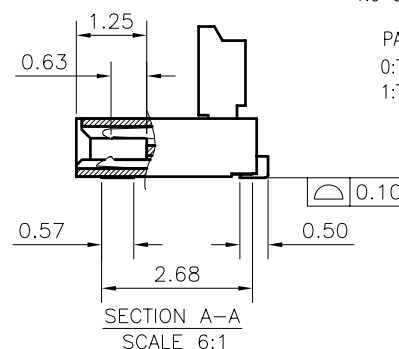
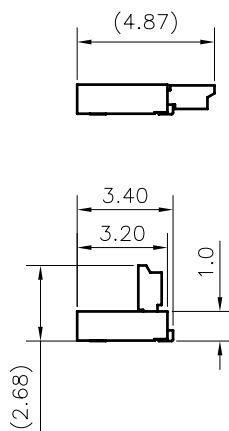
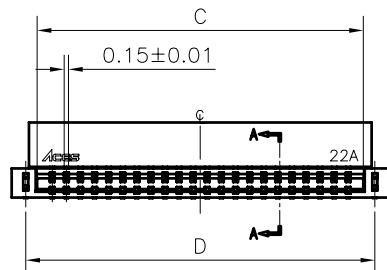

CKT	DIM A	DIM B	DIM C	DIM D	DIM E	DIM F	DIM G
31	17.88	15.00	16.07	16.88	16.60	17.40	16.00
32	18.38	15.50	16.57	17.38	17.10	17.90	16.50
33	18.88	16.00	17.07	17.88	17.60	18.40	17.00
34	19.38	16.50	17.57	18.38	18.10	18.90	17.50

一般公差 TOLERANCES X ±0.5 XX ±0.15 X ±0.25 .XXX ±0.1 ANGLES ±2°		宏致電子股份有限公司 Aces Electronics Co.,Ltd.	
檢驗尺寸標示 SYMBOLS INDICATE CLASSIFICATION DIMENSION MARK IS CRITICAL DIM. MARK IS MAJOR DIM.	品名 (TITLE) 0.5mm Pitch Easy On FFC/FPC Conn.	製圖 (DR) 13/04/03 FENGXIAO 審核 (CHKD) CARL	核準 (APPD) JASON
表面處理 (FINISH)	圖號 (DWG NO.) 51538-XXXX-001	比例 (SCALE) 3:1	單位 (UNITS) mm
			張數 (SHEET) 1 OF 2 尺寸 (SIZE) A4 版次 (REV) B